

REV.	DESCRIPTION	INITIATOR	DATE
03	ECO 21181: Updated servicable item, 3700-20-11225 was 3700-20-9006.	BAW	4/11/2023

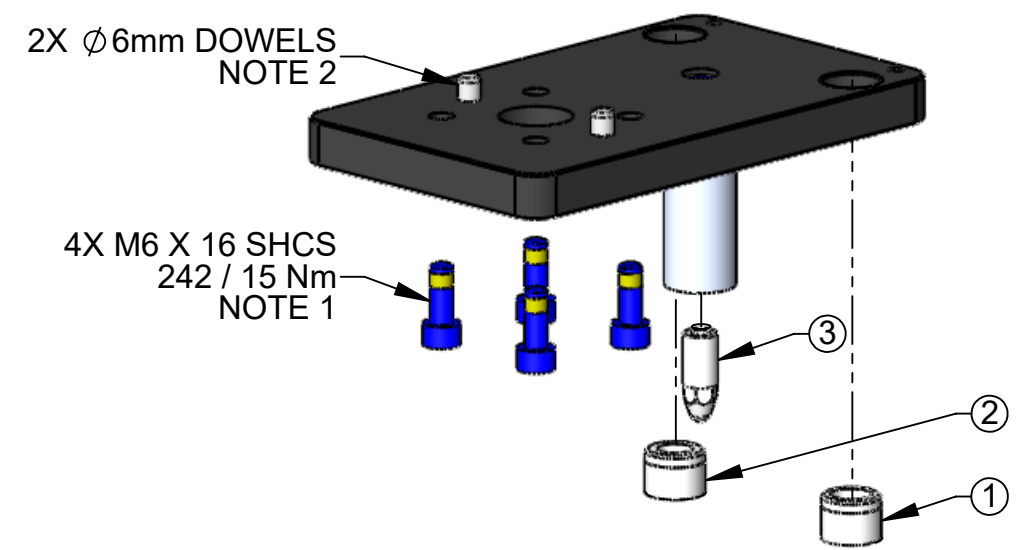
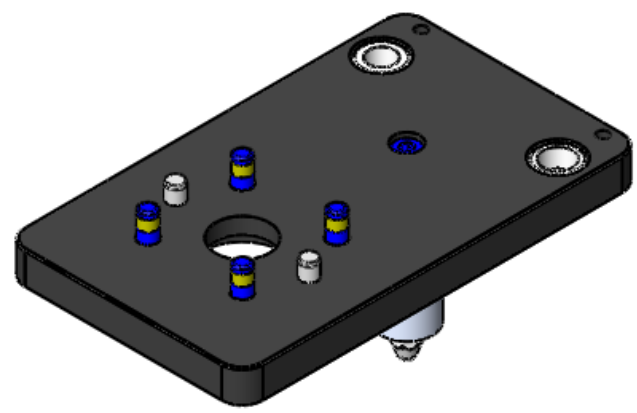
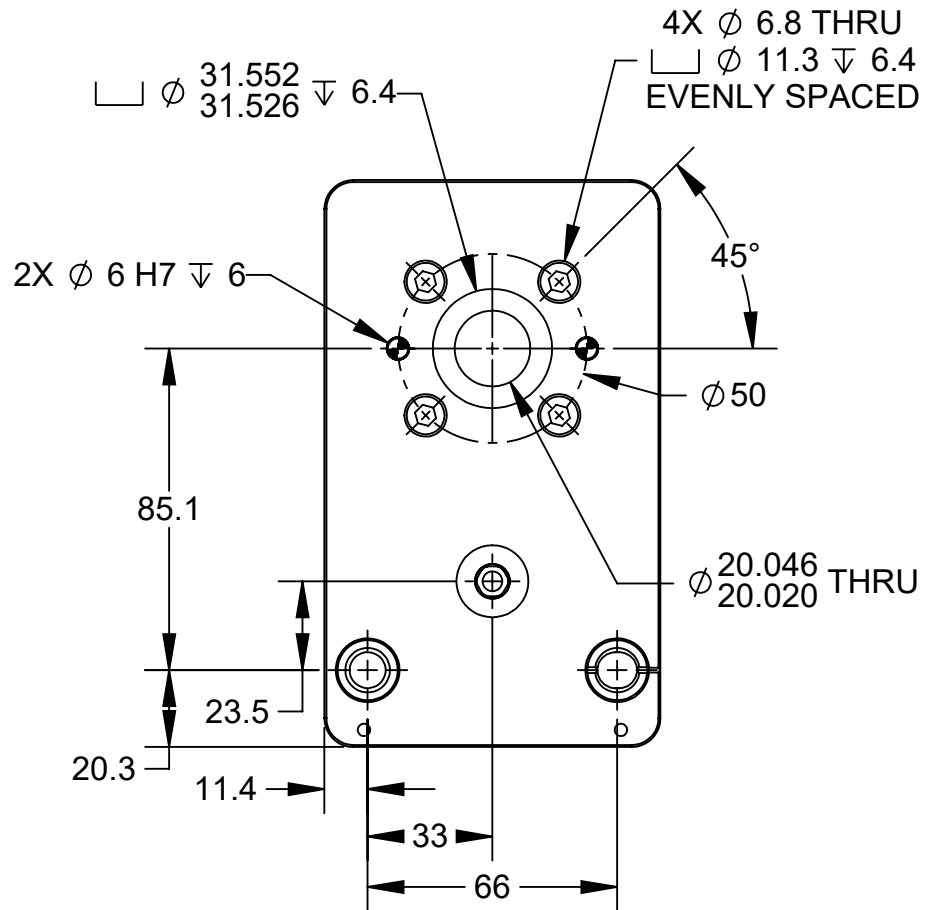
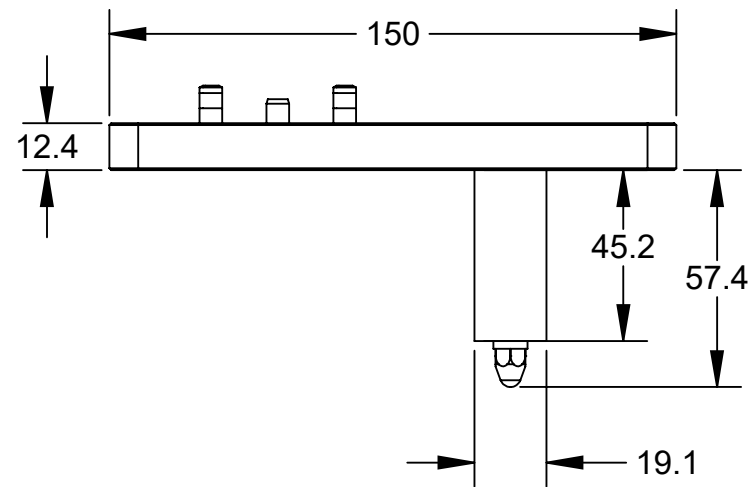
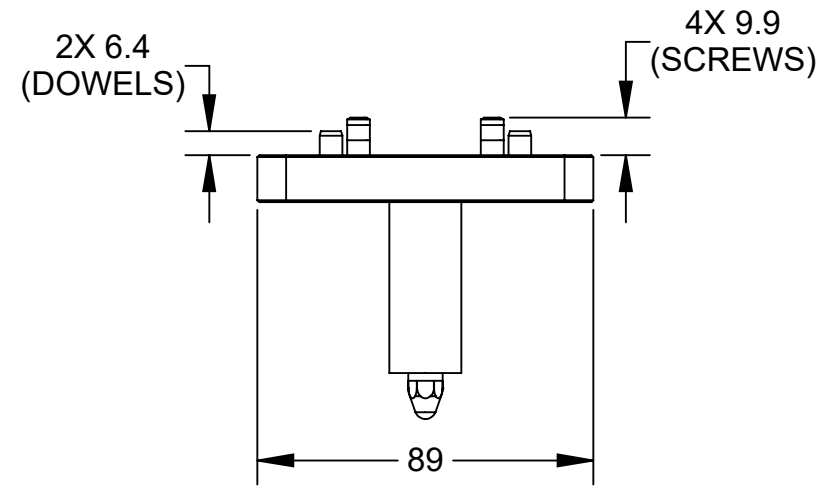

SERVICEABLE ITEMS			
ITEM NO.	QTY	PART NUMBER	DESCRIPTION
1	1	3700-20-5200	ELONGATED DRILL BUSHING 3/8" DIA, 5/8 OD, 1/2" LONG
2	1	3700-20-5230	DRILL BUSHING 3/8ID X 5/8OD X 1/2 L
3	1	3700-20-11225	TSS ALIGNMENT PIN FEMALE

NOTES:
 1. FASTENERS SHIPPED LOOSE. CUSTOMER TO USE LOCTITE OR SIMILAR THREAD LOCKER AND TORQUE TO LISTED VALUE.
 2. PLATE COMES WITH DOWEL PINS PRESSED IN FOR ENGAGING THE QC-29 TOOL.

ITEM NO.	QTY	PART NUMBER	DESCRIPTION
1	1	9120-TSS-HBQ-11659	TSS TOOLING INTERFACE PLATE FOR QC-29 - BLANK

NOTES: UNLESS OTHERWISE SPECIFIED.
 DO NOT SCALE DRAWING. ALL DIMENSIONS ARE IN MILLIMETERS.

ATI INDUSTRIAL AUTOMATION

1031 Goodworth Drive, Apex, NC 27539, USA
 Tel: +1.919.772.0115 www.ati-ia.com
 Fax: +1.919.772.8259 ISO 9001 Registered Company

PROPERTY OF ATI INDUSTRIAL AUTOMATION, INC. NOT TO BE REPRODUCED IN ANY MANNER EXCEPT ON ORDER OR WITH PRIOR WRITTEN AUTHORIZATION OF ATI.

DRAWN BY: M. GALA 5/17/21		TITLE	
CHECKED BY: D. THOMAS 5/26/21		TSS TOOLING INTERFACE PLATE FOR QC-29 - BLANK	
SCALE	SIZE	DRAWING NUMBER	REVISION
1:2	B	9630-20-TSS-HBQ-11659	03

PROJECT # 210421-1 SHEET 1 OF 1

3rd ANGLE PROJECTION